

A.C. ELECTRO HYDRAULIC THRUSTER (EMT-3/ ST 546)

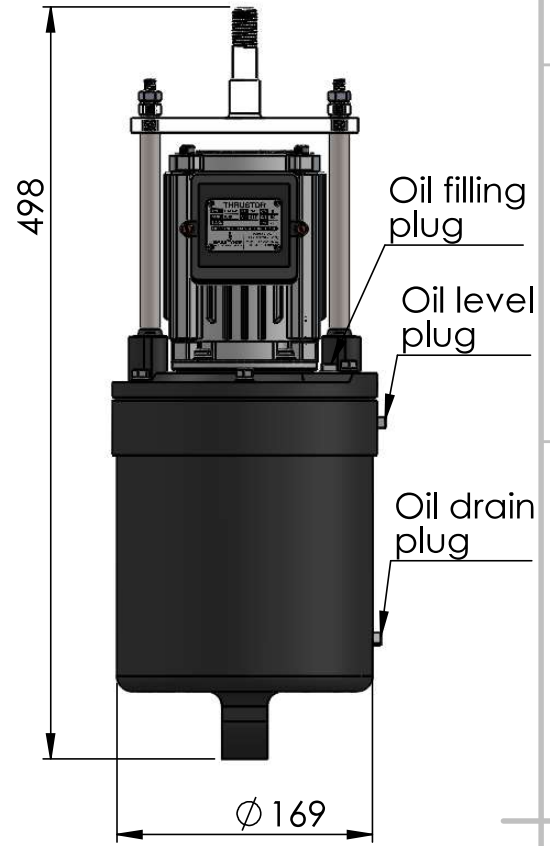
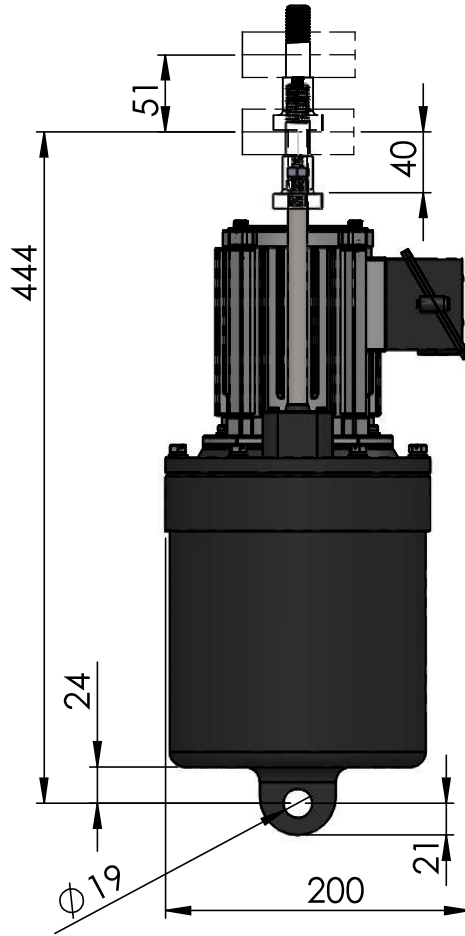

Type	EMT-3/ ST 546
Thrust Capacity (Kg)	46
Thrust stroke (mm)	51
Input Watts	180
Input Supply*	415V/ 3Ø / 50Hz
Oil Capacity (Ltr.)**	2.5
Weight (Kg)	25

Notes:

- Operating position of thruster must be within 10° of the vertical.
- Supply leads must be flexible and allow thruster to pivot.

* Thruster can also be supply with differant voltage and frequency as per customer requirments.

** Oil should be use Transformer Oil BS 148.

UNLESS OTHERWISE SPECIFIED:
DIMENSIONS ARE IN MILLIMETERS
SURFACE FINISH:
TOLERANCES:
LINEAR:
ANGULAR:

FINISH:

DEBURR AND
BREAK SHARP
EDGES

DO NOT SCALE DRAWING

REVISION

Speedage Engineers (India) Pvt. Ltd.

	NAME	SIGNATURE	DATE	CONTACT
DRAWN	Himanshu Tiwari			
CHKD				
APPVD	J.A. Raichandani			9810173991
MFG				

TITLE:

EMT-3/ ST 546

Q.A
THIS DRAWING IS THE PROPERTY OF **SPEEDAGE ENGINEERS (INDIA) PVT. LTD.** & MUST NEITHER BE COPIED NOR BE MADE KNOWN TO ANY OTHER PARTY WITHOUT THEIR PRIOR WRITTEN CONSENT.

MATERIAL:

DWG NO.

SAE/DWG/TH46/01

A4

WEIGHT:

SCALE:1:5

SHEET 1 OF 1